

## Optocoupler, Phototransistor Output, SOP-6L5, 110 °C Rated, Half Pitch, Long Mini-Flat Package

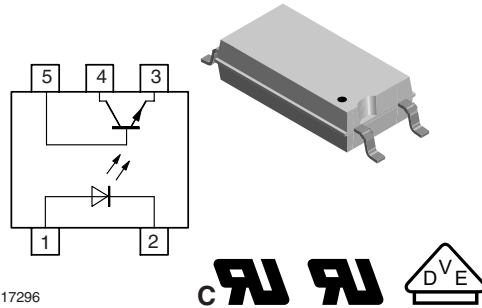

17296

### DESCRIPTION

The TCLT1110 series consists of a phototransistor optically coupled to a gallium arsenide infrared-emitting diode in a 5-lead SOP-6L package.

The elements are mounted on one leadframe providing a fixed distance between input and output for highest safety requirements.

### FEATURES

- SMD low profile 5 pin package
- Isolation test voltage 5000 V<sub>RMS</sub>
- CTR flexibility available see order information
- Special construction
- Extra low coupling capacitance
- Connected base
- DC input with transistor output
- Temperature range - 40 °C to 110 °C
- Thickness through insulation ≥ 0.75 mm
- Creepage distance > 8 mm
- Lead (Pb)-free component
- Component in accordance to RoHS 2002/95/EC and WEEE 2002/96/EC



**RoHS**  
COMPLIANT

### AGENCY APPROVALS

- UL1577, file no. E76222 system code W, double protection
- CUL - file no. E52744, equivalent to CSA 22.2 bulletin 5A
- DIN EN 60747-5-2 (VDE 0884)

### APPLICATIONS

- Switchmode power supplies
- Computer peripheral interface
- Microprocessor system interface

ORDER INFORMATION	
PART	REMARKS
TCLT1110	CTR 50 to 600 %, SOP-6L5
TCLT1111	CTR 40 to 80 %, SOP-6L5
TCLT1112	CTR 63 to 125 %, SOP-6L5
TCLT1113	CTR 100 to 200 %, SOP-6L5
TCLT1114	CTR 160 to 320 %, SOP-6L5
TCLT1115	CTR 50 to 150 %, SOP-6L5
TCLT1116	CTR 100 to 300 %, SOP-6L5
TCLT1117	CTR 80 to 160 %, SOP-6L5
TCLT1118	CTR 130 to 260 %, SOP-6L5
TCLT1119	CTR 200 to 400 %, SOP-6L5

### Note

Available only on tape and reel.

# TCLT1110 Series



Vishay Semiconductors Optocoupler, Phototransistor Output,  
SOP-6L5, 110 °C Rated,  
Half Pitch, Long Mini-Flat Package

ABSOLUTE MAXIMUM RATINGS (1)				
PARAMETER	TEST CONDITION	SYMBOL	VALUE	UNIT
<b>INPUT</b>				
Reverse voltage		$V_R$	6	V
Forward current		$I_F$	60	mA
Forward surge current	$t_p \leq 10 \mu s$	$I_{FSM}$	1.5	A
Power dissipation		$P_{diss}$	100	mW
Junction temperature		$T_j$	125	°C
<b>OUTPUT</b>				
Collector emitter voltage		$V_{CEO}$	70	V
Emitter collector voltage		$V_{ECO}$	7	V
Collector current		$I_C$	50	mA
Collector peak current	$t_p/T = 0.5, t_p \leq 10 ms$	$I_{CM}$	100	mA
Power dissipation		$P_{diss}$	150	mW
Junction temperature		$T_j$	125	°C
<b>COUPLER</b>				
Isolation test voltage (RMS)		$V_{ISO}$	5000	$V_{RMS}$
Total power dissipation		$P_{tot}$	250	mW
Operating ambient temperature range		$T_{amb}$	- 40 to + 110	°C
Storage temperature range		$T_{stg}$	- 40 to + 110	°C
Soldering temperature (2)		$T_{sld}$	260	°C

## Notes

(1)  $T_{amb} = 25 \text{ }^\circ\text{C}$ , unless otherwise specified.

Stresses in excess of the absolute Maximum Ratings can cause permanent damage to the device. Functional operation of the device is not implied at these or any other conditions in excess of those given in the operational sections of this document. Exposure to absolute Maximum Rating for extended periods of the time can adversely affect reliability.

(2) Refer to reflow profile for soldering conditions for surface mounted devices.

ELECTRICAL CHARACTERISTICS						
PARAMETER	TEST CONDITION	SYMBOL	MIN.	TYP.	MAX.	UNIT
<b>INPUT</b>						
Forward voltage	$I_F = 50 \text{ mA}$	$V_F$		1.25	1.6	V
Junction capacitance	$V_R = 0 \text{ V}, f = 1 \text{ MHz}$	$C_j$		50		pF
<b>OUTPUT</b>						
Collector emitter voltage	$I_C = 1 \text{ mA}$	$V_{CEO}$	70			V
Emitter collector voltage	$I_E = 100 \mu\text{A}$	$V_{ECO}$	7			V
Collector emitter cut-off current	$V_{CE} = 20 \text{ V}, I_F = 0 \text{ A}, E = 0$	$I_{CEO}$		10	100	nA
<b>COUPLER</b>						
Collector emitter saturation voltage	$I_F = 10 \text{ mA}, I_C = 1 \text{ mA}$	$V_{CEsat}$			0.3	V
Cut-off frequency	$V_{CE} = 5 \text{ V}, I_F = 10 \text{ mA}, R_L = 100 \Omega$	$f_c$		110		kHz
Coupling capacitance	$f = 1 \text{ MHz}$	$C_k$		0.3		pF

## Note

$T_{amb} = 25 \text{ }^\circ\text{C}$ , unless otherwise specified.

Minimum and maximum values are testing requirements. Typical values are characteristics of the device and are the result of engineering evaluation. Typical values are for information only and are not part of the testing requirements.



Optocoupler, Phototransistor Output,  
SOP-6L5, 110 °C Rated,  
Half Pitch, Long Mini-Flat Package

Vishay Semiconductors

<b>CURRENT TRANSFER RATIO</b>							
PARAMETER	TEST CONDITION	PART	SYMBOL	MIN.	TYP.	MAX.	UNIT
I <sub>C</sub> /I <sub>F</sub>	V <sub>CE</sub> = 5 V, I <sub>F</sub> = 5 mA	TCLT1110	CTR	50		600	%
	V <sub>CE</sub> = 5 V, I <sub>F</sub> = 10 mA	TCLT1111	CTR	40		80	%
		TCLT1112	CTR	63		125	%
		TCLT1113	CTR	100		200	%
		TCLT1114	CTR	160		320	%
	V <sub>CE</sub> = 5 V, I <sub>F</sub> = 1 mA	TCLT1111	CTR	13	30		%
		TCLT1112	CTR	22	45		%
		TCLT1113	CTR	34	70		%
		TCLT1114	CTR	56	100		%
	V <sub>CE</sub> = 5 V, I <sub>F</sub> = 5 mA	TCLT1115	CTR	50		150	%
		TCLT1116	CTR	100		300	%
		TCLT1117	CTR	80		160	%
		TCLT1118	CTR	130		260	%
TCLT1119		CTR	200		400	%	

<b>MAXIMUM SAFETY RATINGS</b>						
PARAMETER	TEST CONDITION	SYMBOL	MIN.	TYP.	MAX.	UNIT
<b>INPUT</b>						
Forward current		I <sub>F</sub>			130	mA
<b>OUTPUT</b>						
Power dissipation		P <sub>diss</sub>			265	mW
<b>COUPLER</b>						
Rated impulse voltage		V <sub>IOTM</sub>			8	kV
Safety temperature		T <sub>si</sub>			150	°C

**Note**

According to DIN EN 60747-5-2 (VDE 0884)/DIN EN 60747-5-5 pending (see figure 1). This optocoupler is suitable for safe electrical isolation only within the safety ratings. Compliance with the safety ratings shall be ensured by means of suitable protective circuits.

<b>INSULATION RATED PARAMETERS</b>						
PARAMETER	TEST CONDITION	SYMBOL	MIN.	TYP.	MAX.	UNIT
Partial discharge test voltage - routine test	100 %, t <sub>test</sub> = 1 s	V <sub>pd</sub>	1.6			kV
Partial discharge test voltage - lot test (sample test)	t <sub>Tr</sub> = 60 s, t <sub>test</sub> = 10 s, (see figure 2)	V <sub>IOTM</sub>	8			kV
		V <sub>pd</sub>	1.3			kV
Insulation resistance	V <sub>IO</sub> = 500 V	R <sub>IO</sub>	10 <sup>12</sup>			Ω
	V <sub>IO</sub> = 500 V, T <sub>amb</sub> = 100 °C	R <sub>IO</sub>	10 <sup>11</sup>			Ω
	V <sub>IO</sub> = 500 V, T <sub>amb</sub> = 150 °C (construction test only)	R <sub>IO</sub>	10 <sup>9</sup>			Ω

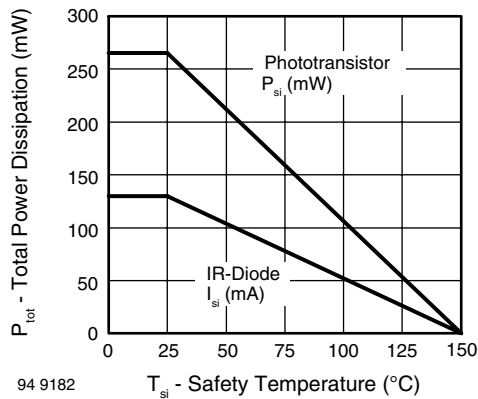

Fig. 1 - Derating Diagram

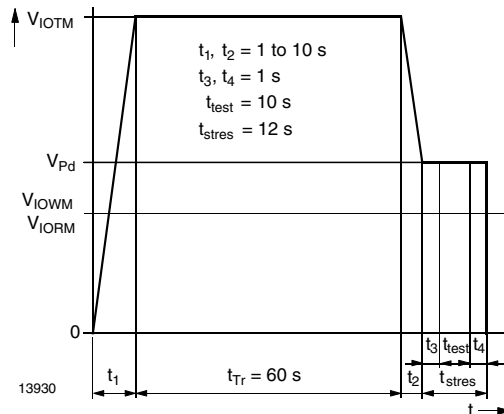
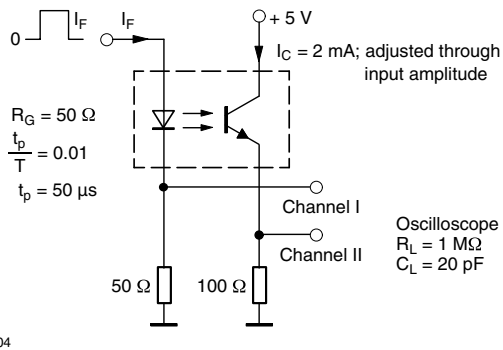

Fig. 2 - Test Pulse Diagram for Sample Test According to DIN EN 60747-5-2 (VDE 0884)/DIN EN 60747-; IEC60747

SWITCHING CHARACTERISTICS						
PARAMETER	TEST CONDITION	SYMBOL	MIN.	TYP.	MAX.	UNIT
Delay time	$V_S = 5\text{ V}$ , $I_C = 2\text{ mA}$ , $R_L = 100\ \Omega$ , (see figure 3)	$t_d$		3.0		$\mu\text{s}$
Rise time	$V_S = 5\text{ V}$ , $I_C = 2\text{ mA}$ , $R_L = 100\ \Omega$ , (see figure 3)	$t_r$		3.0		$\mu\text{s}$
Fall time	$V_S = 5\text{ V}$ , $I_C = 2\text{ mA}$ , $R_L = 100\ \Omega$ , (see figure 3)	$t_f$		4.7		$\mu\text{s}$
Storage time	$V_S = 5\text{ V}$ , $I_C = 2\text{ mA}$ , $R_L = 100\ \Omega$ , (see figure 3)	$t_s$		0.3		$\mu\text{s}$
Turn-on time	$V_S = 5\text{ V}$ , $I_C = 2\text{ mA}$ , $R_L = 100\ \Omega$ , (see figure 3)	$t_{on}$		6.0		$\mu\text{s}$
Turn-off time	$V_S = 5\text{ V}$ , $I_C = 2\text{ mA}$ , $R_L = 100\ \Omega$ , (see figure 3)	$t_{off}$		5.0		$\mu\text{s}$
Turn-on time	$V_S = 5\text{ V}$ , $I_F = 10\text{ mA}$ , $R_L = 1\text{ k}\Omega$ , (see figure 4)	$t_{on}$		9.0		$\mu\text{s}$
Turn-off time	$V_S = 5\text{ V}$ , $I_F = 10\text{ mA}$ , $R_L = 1\text{ k}\Omega$ , (see figure 4)	$t_{off}$		10.0		$\mu\text{s}$



95 10804

Fig. 3 - Test Circuit, Non-Saturated Operation

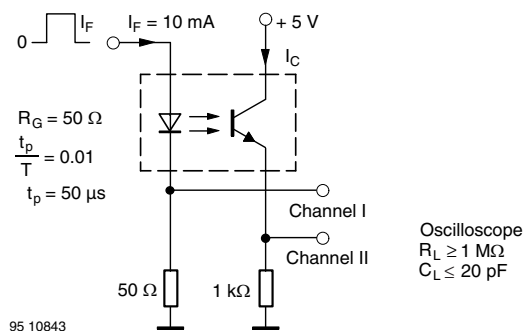

95 10843

Fig. 4 - Test Circuit, Saturated Operation

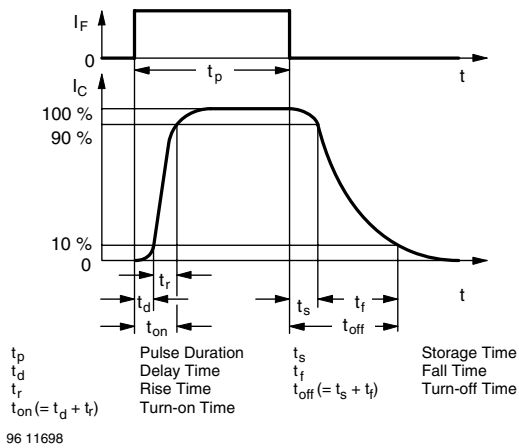

Fig. 5 - Switching Times

**TYPICAL CHARACTERISTICS**

$T_{amb} = 25\text{ °C}$ , unless otherwise specified

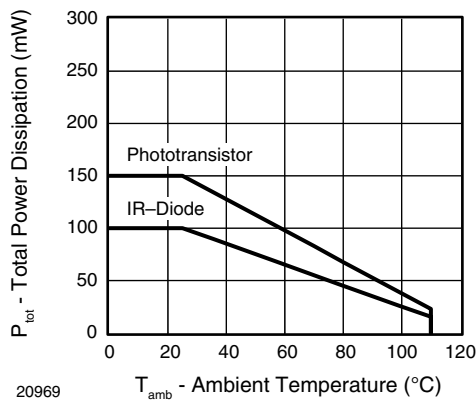

Fig. 6 - Total Power Dissipation vs. Ambient Temperature

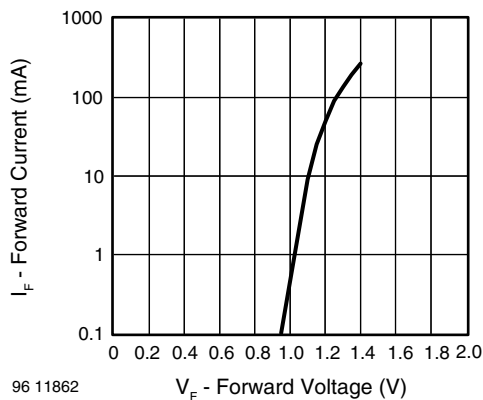

Fig. 7 - Forward Current vs. Forward Voltage

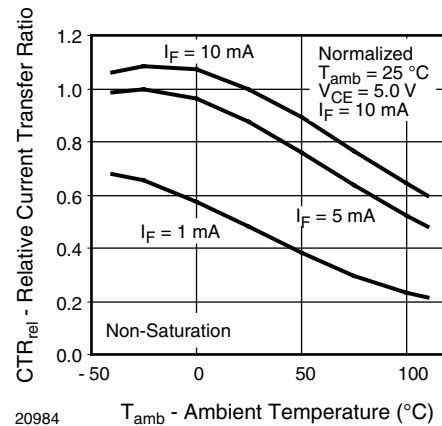

Fig. 8 - Relative Current Transfer Ratio vs. Ambient Temperature

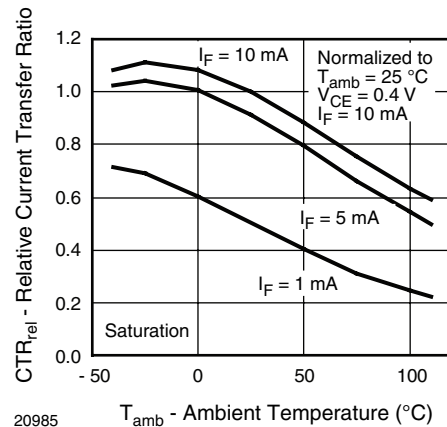

Fig. 9 - Relative Current Transfer Ratio vs. Ambient Temperature

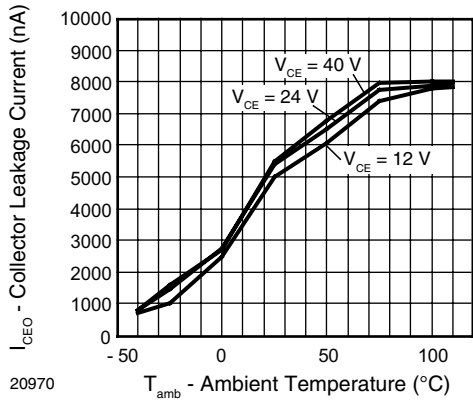

Fig. 10 - Collector Leakage Current vs. Ambient Temperature

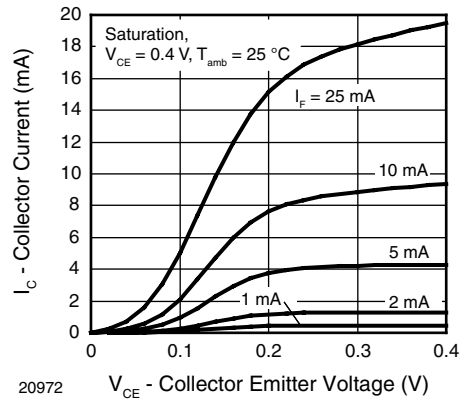

Fig. 13 - Collector Current vs. Collector Emitter Voltage

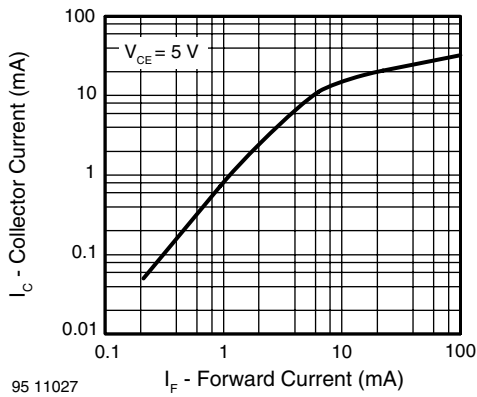

Fig. 11 - Collector Current vs. Forward Current

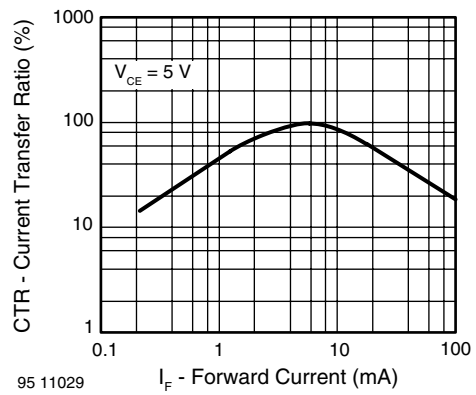

Fig. 14 - Current Transfer Ratio vs. Forward Current

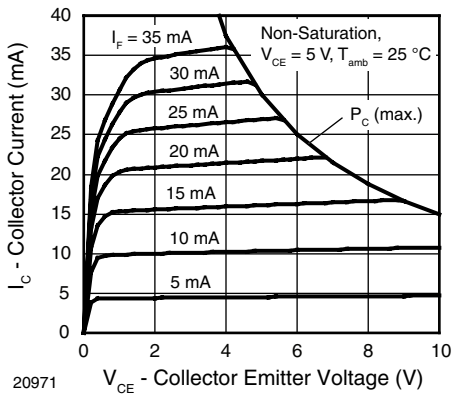

Fig. 12 - Collector Current vs. Collector Emitter Voltage

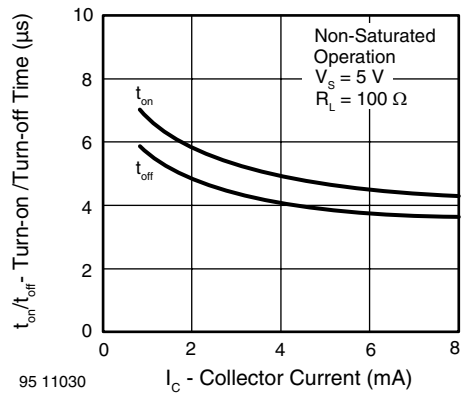

Fig. 15 - Turn-on/off Time vs. Collector Current

Optocoupler, Phototransistor Output,  
SOP-6L5, 110 °C Rated,  
Half Pitch, Long Mini-Flat Package

Vishay Semiconductors

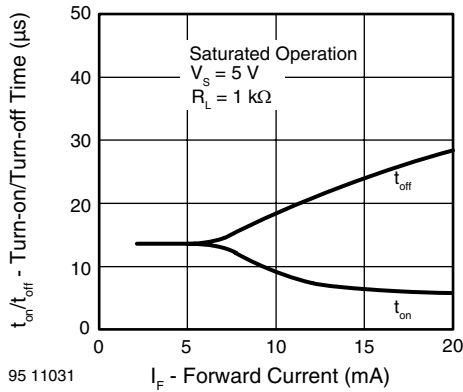
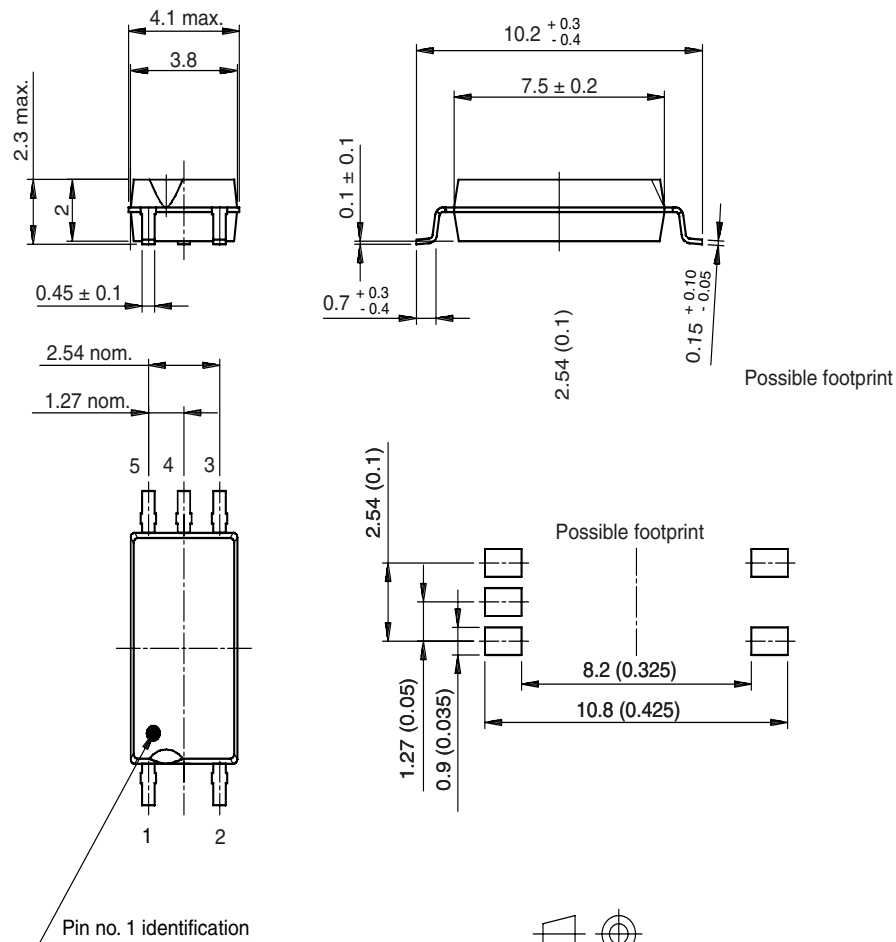

Fig. 16 - Turn-on/off Time vs. Forward Current

**PACKAGE DIMENSIONS** in millimeters (inches)



Drawing-No.: 6.544-5331.02-4  
Issue: 2; 29.06.00

technical drawings  
according to DIN  
specifications

15227

Vishay Semiconductors Optocoupler, Phototransistor Output,  
SOP-6L5, 110 °C Rated,  
Half Pitch, Long Mini-Flat Package

## **OZONE DEPLETING SUBSTANCES POLICY STATEMENT**

It is the policy of Vishay Semiconductor GmbH to

1. Meet all present and future national and international statutory requirements.
2. Regularly and continuously improve the performance of our products, processes, distribution and operating systems with respect to their impact on the health and safety of our employees and the public, as well as their impact on the environment.

It is particular concern to control or eliminate releases of those substances into the atmosphere which are known as ozone depleting substances (ODSs).

The Montreal Protocol (1987) and its London Amendments (1990) intend to severely restrict the use of ODSs and forbid their use within the next ten years. Various national and international initiatives are pressing for an earlier ban on these substances.

Vishay Semiconductor GmbH has been able to use its policy of continuous improvements to eliminate the use of ODSs listed in the following documents.

1. Annex A, B and list of transitional substances of the Montreal Protocol and the London Amendments respectively.
2. Class I and II ozone depleting substances in the Clean Air Act Amendments of 1990 by the Environmental Protection Agency (EPA) in the USA.
3. Council Decision 88/540/EEC and 91/690/EEC Annex A, B and C (transitional substances) respectively.

Vishay Semiconductor GmbH can certify that our semiconductors are not manufactured with ozone depleting substances and do not contain such substances.

We reserve the right to make changes to improve technical design  
and may do so without further notice.

Parameters can vary in different applications. All operating parameters must be validated for each customer application by the customer. Should the buyer use Vishay Semiconductors products for any unintended or unauthorized application, the buyer shall indemnify Vishay Semiconductors against all claims, costs, damages, and expenses, arising out of, directly or indirectly, any claim of personal damage, injury or death associated with such unintended or unauthorized use.

Vishay Semiconductor GmbH, P.O.B. 3535, D-74025 Heilbronn, Germany





## Disclaimer

All product specifications and data are subject to change without notice.

Vishay Intertechnology, Inc., its affiliates, agents, and employees, and all persons acting on its or their behalf (collectively, "Vishay"), disclaim any and all liability for any errors, inaccuracies or incompleteness contained herein or in any other disclosure relating to any product.

Vishay disclaims any and all liability arising out of the use or application of any product described herein or of any information provided herein to the maximum extent permitted by law. The product specifications do not expand or otherwise modify Vishay's terms and conditions of purchase, including but not limited to the warranty expressed therein, which apply to these products.

No license, express or implied, by estoppel or otherwise, to any intellectual property rights is granted by this document or by any conduct of Vishay.

The products shown herein are not designed for use in medical, life-saving, or life-sustaining applications unless otherwise expressly indicated. Customers using or selling Vishay products not expressly indicated for use in such applications do so entirely at their own risk and agree to fully indemnify Vishay for any damages arising or resulting from such use or sale. Please contact authorized Vishay personnel to obtain written terms and conditions regarding products designed for such applications.

Product names and markings noted herein may be trademarks of their respective owners.